

# CVC1266 Plastic Bottle Unscrambler

- Lower Operating Costs

- Increase Operating Flexibility

- Unparalleled Service

- Quality that your Customers Demand



The CVC1266 Bottle Unscrambler is designed to automatically feed bottles from a bin and place them upright onto a conveyor at speeds of up to 200-250 bottles per minute. The CVC1266 is PLC controlled and comes standard with a 6" touch screen panel. Options include ionized air rinse with vacuum, fallen bottle sensor with return to bin, low level hopper sensor, tower lamp, and static eliminator bar. \*No "chute" change parts required

• Built to cGMP Standards • Stainless Steel Construction • 10 Channels of Memory • Quick & Easy Change Over

Solid Dose Bottling Lines

Blister Packaging  
Cartoners  
Labelers

"Leading Global Equipment Supplier"

[www.cvcusa.com](http://www.cvcusa.com)



**CVC Technologies, Inc.**

# CVC1266 Technical Specifications

## Standard Features:

- 6" PLC Controlled Touch Screen Display
- Display Touch Screen Instruction for machine operation is available in two languages
- SS304 Stainless Steel bin, frame, enclosure panels
- Memory capacity for 10 jobs
- Interlocked Safety Shield
- Low Level hopper sensor
- Bottle backlog sensor at outfeed
- Machine Capacity: up to 200-250 bottles per minute (BPM)
- ISO 9001:2000 Certified

## Container Specifications:

- Bottle Height: 1.77" to 7.87" (45mm - 200mm)
- Bottle Diameter: 1.18" to 4.72" (30mm - 120mm)
- Neck Opening: 0.98" to 3.34" (25mm - 85mm)
- Minimum Bottle height/dia. ratio: 1.5 : 1
- Bottle height up to Shoulder: Min. 1.77" (45mm)

## Machine Specifications:

- Machine Dimensions: 2,297(L) X 1,233(W) X 1,510(H) mm
- Hopper Capacity: 14 cu. ft.
- Machine Weight: 1,940 Lbs. (880 kg)
- Packing Weight: 2,524 lbs. (1,145 kg)
- Noise Level: 78 dB

## Air/Electrical Requirements:

- Power Source: 220V, 50/60 Hz, Single Phase
- Power Consumption: 5 Amp  
(9 Amp when equipped with Air Rinse & Vacuum)
- Air Pressure: Minimum 85 psi (ISO 8573-1)
- Air Consumption: 3.5 cfm (100 liters / sq.cm) Standard Machine  
Without Optional Ionized Air Rinse Assembly. (28 cfm when equipped With Air Rinse Assembly)

## Available Options:

- Static eliminator bar in disc sorter
- Ionized air rinsing assembly with collection tray
- Upside down bottle, fallen bottle reject assembly
- Pre-sorter disc
- Siemens Controls and HMI
- Tower lamp

## Machine Layouts:

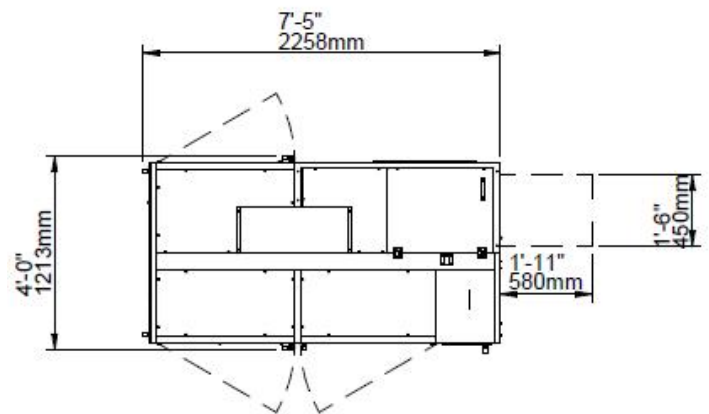

Top View

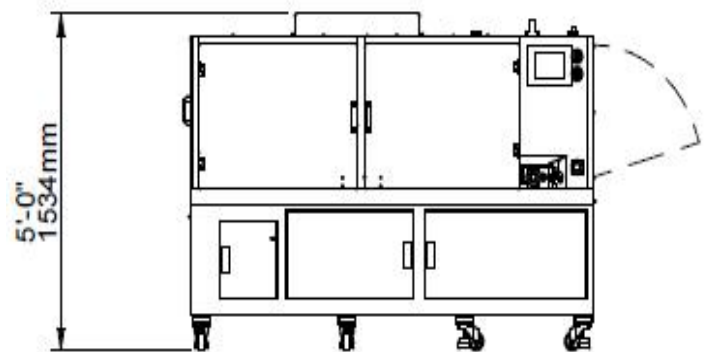

Front View



Quality • Value • Service

Authorized CVC Dealer

Copyright © CVC Technologies, Inc. • April 2013 Edition

*Dimensions shown are for a standard machine. This machine can run independently or can be integrated into an automated packaging line. All CVC equipment is covered by a one year parts warranty. Full Warranty details are included in our equipment proposals or can be found on our website.*